

ELECTRICAL RESISTIVITY MEASUREMENTS OF DOWNSCALED HOMOGENOUS ROCKS FOR NETWORK MODEL VALIDATION

O.A. Olafuyi^{a,b}, A.A. Ikhouria^a, S.A. Akintola^c

^aDEPARTMENT OF PETROLEUM ENGINEERING, UNIVERSITY OF BENIN, EDO STATE, NIGERIA

^bEmail: abdulkashif@yahoo.com

^cDEPARTMENT OF PETROLEUM ENGINEERING, UNIVERSITY OF IBADAN, IBADAN, NIGERIA

Abstract

Knowledge of electrical resistivity for reservoir rocks is crucial for a number of reservoir engineering tasks such as the determination of oil-in-place and the calibration of resistivity logs. Those properties can now be predicted by numerical calculations directly on micro-CT images taken from rock fragments typically having a bulk volume of 100mm³. The experimental data used to validate those predictions are obtained on conventional cores having bulk volumes of the order of 10,000mm³. A better validation of micro-CT technique would be to use the same core size for both imaging and flow experiment. Experimental data for electrical resistivity measurements using micropore membrane and centrifuge desaturation techniques are presented for cores having bulk volumes from 10,000mm³ down to 100mm³. Both 2 - and 4 - electrode techniques were applied to measure the resistivity index. Simple fluids like brine and air were used for clear wettability. Homogeneous sandstone cores (Berea and Bentheim) and a carbonate core (Mount Gambier) were used in the experiments. The results demonstrate that reliable experimental data of resistivity index can be obtained for the small cores of homogeneous porous rocks at sensitized frequency. Such data are of immense interest for validating the predictive value of network models based on micro-CT imaging of rock fragments with bulk volumes as small as 100 mm³.

Keywords: resistivity index, micro-CT, frequency, homogenous, downscaling

1. Introduction

About 50% of discovered oil remains unrecovered from the reservoir, and with the increase in demand for crude oil as well as depleting world oil reserves, there is a global concern on the limited number of consumption years left. Detailed characterization of virgin oil fields and proper planning of enhanced oil recovery (EOR) process on the producing field are the hope to keep up with these demands. Hydrocarbon reservoir characterization relies

on laboratory measurements made on few core samples, which are then used to calibrate well logs and to obtain multiphase flow transport properties. Few core samples from selected zones in the reservoir may not be adequate to represent real structure of a reservoir because reservoirs are never homogenous. Thus multiphase transport properties obtained from few core samples may introduce an enormous error in field scale simulations and production forecasts.

Recent advances in imaging technology now make it possible to routinely image rock microstructure in 3D at the pore scale. Coupling this with an ability to computationally predict petrophysical and multiphase flow properties directly on the 3D digitised tomographic images or on equivalent networks (digital core technology) results in a powerful tool to interpret conventionally measured core data and to extend the range of available data by examining rock fragments which cannot be tested by conventional means (sidewall cores, drill cuttings and unconsolidated or poorly consolidated rocks). A number of studies[1-3] suggest that computations of permeability, formation factor and mercury injection capillary pressure on digitised image of a small rock fragment cut from a core plug are consistent with laboratory measurements performed on the same plug even though the computations and measurements are performed at significantly different scales.

Micro-CT imaging is currently limited to small sample sizes; pore scale imaging on most materials requires resolutions of 3-5 microns, and image size is limited to approximately 2000 cubed this limits the sample sizes for imaging studies to 5mm-10mm which is significantly smaller than conventional core plug scale. Moreover, computational times usually limit the computational domain used to a smaller sub-set of the imaged volume. Conventional laboratory measurements, on the other hand, are carried on core plugs and composite cores at scales several orders of magnitude larger than that for the image based computations.

Effect of sample sizes on multiphase transport properties has been reported for capillary pressure[4] and spontaneous imbibitions measurements[5]. These were investigated by performing laboratory measurements at a number of different scales from the core plug scale down to a scale closer to that imaged using micro-CT. The investigation was limited to rocks that are usually considered to be homogeneous or model rock types. These are

the rock types normally used to validate image based calculations of a wide range of rock properties.

Electrical resistivity is a physical quantity that measures how strongly a material opposes the flow of electric current. Archie's second equation[6] describes the resistivity changes caused by hydrocarbon saturation. Resistivity index, I , was defined as the ratio of the measured resistivity of the rock, R_t , to its resistivity when fully saturated with water, R_o . He proposed that I is controlled by the reciprocal of the fractional water saturation, S_w , to a power of n , which is known as saturation exponent (Eqs. 1 and 2).

$$S_w = \left(\frac{R_o}{R_t} \right)^{\frac{1}{n}} \quad (1)$$

$$I = \frac{R_t}{R_o} = S_w^{-n} \quad (2)$$

A log-log plot of I versus S_w , is usually assumed to be linear yield a slope of $-n$ where n is generally assumed to be equal to 2.

Various researchers have applied electrical resistivity in different areas of multiphase flow in porous media especially in the oil and gas industry. These areas include: the estimation of the saturation of connate water and oil-in-place of oil bearing rocks[611]; the calibration of the well logs[12]; classifying a hydrocarbon-bearing reservoir rock[9]; calibrating/validating Archie equation for carbonate rocks[810,1315]; the evaluation and characterization of wettability of a reservoir at in-situ conditions by studying the dielectric spectra at various frequencies[14,16-17]; modeling hydrocarbon displacement by water spontaneous imbibition and/or water injection with combined resistivity - saturation and capillary pressure - saturation functions[11]; laboratory study of saturation variation in partially saturated rocks[6,8-10,14]; determination of height of the transition zone (oil or gas water contact)[8-10] etc.

Network models, in which the pore-space of a porous rock is represented by a network of

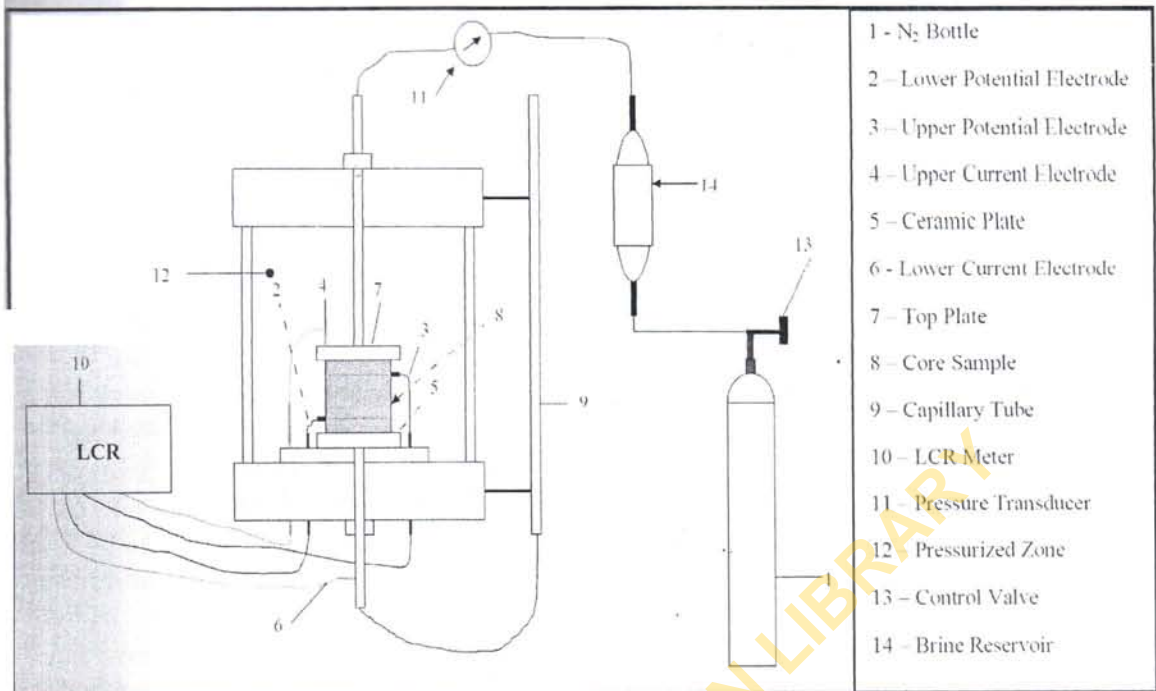

Figure 1: Schematic of Pc-RI Equipment.

interconnected pores and throats, have great potentials to accurately predict electrical resistivity of reservoir rocks but the effect of core sample size needs to be investigated. Although these effect have been reported to be negligible for capillary pressure[4] and spontaneous imbibition[5] measurements, the properties of reservoir rocks that affects electrical resistivity measurements differ.

A great deal of research has been done to assess the influence of operating conditions, fluids and rock properties on electrical properties of a porous rock. Various factors that affect the electrical resistivity of rocks fully and partially saturated with reservoir fluids include confining pressure[18-22], wettability[23,24], pore structure[25,26], microporosity[27-32], frequency[33,34], desaturation technique[35] and electrode polarization[15]. Detailed reviews of these factors have been reported in the literature[36]. However, none of the literature reported the effect of sample size and electrode spacing with effect of frequency on electrical resistivity measurement. This is of paramount importance

in obtaining a realistic experimental data for network model validation. Thus, a clear need exists to check the effect of size and electrode spacing on electrical resistivity measurements.

2. Experimental Approach

2.1. Laboratory Apparatus

The electrical resistivity measurements were performed using the ErgoTech. Mk4 Modular Pc/RI system (Fig. 1 shows the schematics). This equipment was designed for both drainage capillary pressure and electrical resistivity measurements. The electrical resistivity can be measured by both 2- and 4-electrode techniques. In this experiment, the desaturation is achieved by porous plate displacement for A-samples and Centrifuge desaturation technique under controlled environment for B-samples (Fig. 2). The schematic flow diagram for A-samples as shown in Fig. 1; current enters from the top of the sample (4) and leaves the sample via the bottom electrode (6) that is in contact with the porous diaphragm. Electrodes (2)

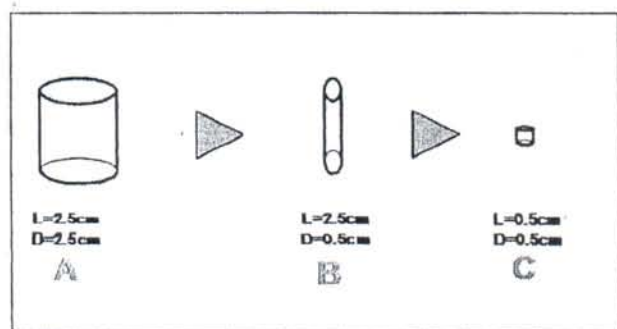

Figure 2: Schematic of the Downscaled Rock Samples.

and (3) measure the current drop along the two electrodes which is translated directly to electrical resistance on the LCR meter (10). The LCR-meter 4263B with 0.1milliohms precision, manufactured by Agilent can operate at frequency range of 100Hz to 120 KHz. B-samples were measured using a typical Wheatstone Bridge set up as shown in Fig. 3 and desaturation achieved by centrifuging at different angular velocity. The same LCR-meter was used for the experiments for consistency. The premises at which the testing takes place were kept at a constant temperature of 22°C so as to avoid any influence of temperature on resistance measurement variation. Also to avoid any influence from temperature variation on gas pressure, viscosity and surface tension of the fluids used. For the A-samples experiments, the total fluid expelled towards the graduating tubes after equilibrium was used to calculate the water saturations of the sample at any particular point while a precision scale with an accuracy of 0.1mg was used to weigh the samples at different desaturation point using centrifuge machine.

2.2. Porous Media

Three model core samples namely, Berea and Bentheimer sandstones and Mount Gambier carbonates were used for the experiments. Their dimensions are tabulated in Table-1.

Table 1: Cores dimensions used in electrical resistivity experiments.

Samples	A	B
Berea	L=26.1mm, D=26.2mm	L=25mm, D=5mm
Bentheimer	L=25.6mm, D=25.6mm	L=25mm, D=5mm
Mount Gambier	L=27.1mm, D=24.9mm	L=28.5mm, D=5.3mm

2.3. Fluids

Brine (2% by weight NaCl) and air were used as the wetting and the non-wetting phases, respectively. The density and viscosity of brine were measured to be 1.066 g/cm³ and 1.0 cp while 0.00129 g/cm³ and 0.0185 cp were used for the density and viscosity of air, respectively. The surface tension for the brine-air system was reported to be 72 mN/m [37]. The selection of brine concentration was based on the water sensitivity analysis carried out by Mohan et al[38]. Berea sandstone, a reference sandstone in the oil and gas industries, contains dispersed clays, which constitute approximately 8% by weight of the sandstone, and no swelling clays. The relative weight in percentages of the clay minerals in Berea sandstone are 71% Kaolinite, 14% of Chlorite, and 15% of Illite/Mica. Bentheimer sandstone is also of importance in oil and gas industries because it is easy to model and study due to its high permeability, high porosity and low clay content. It contains 4-6% clay by weight, in which Kaolinite is about 90% and Cherts 10%. Mount Gambier is a good model carbonate that was discovered not long ago. This particular carbonate sample is important because of its high permeability and porosity, thus, it makes it easier to model and represent the micropores easily.

2.4. Core Preparation

The core samples used in all the experiments were drilled using one-inch coring bit. After coring, the samples are cut to various lengths using Buehler high precision saw. Brine (0.4% NaCl by weight) was used as the drilling fluid to reduce the reactivity of the clay if water had been used [38]. The samples are then dried in humidified oven at 90°C for 24 hours. After drying, the sandstones were

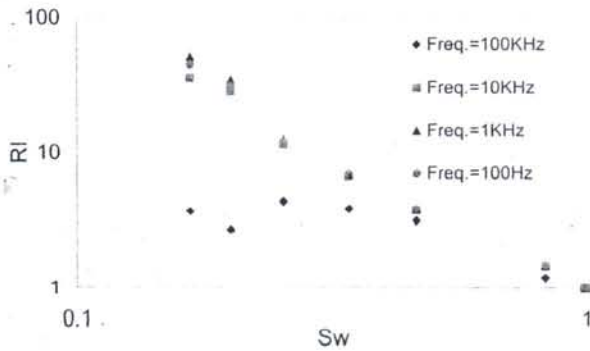
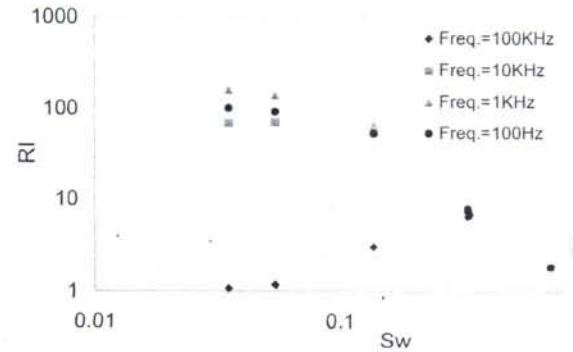
Figure 4: RI- S_w for Berea Sandstone.Figure 5: RI- S_w for Bentheim Sandstone.

increase in the saturation exponent n at low water saturation shed more light on the microstructural properties of rocks. It is difficult to determine representative pore structure or shape in the laboratory during the resistivity measurement. Although the numerical investigation conducted by Sunan and Knight[25] using network model shows an insignificant effect when the porous media is strongly water-wet. This is not in agreement with the observation from Arns et al.[26] studies on Berea network. Arns et al.[26] reported that as the saturation exponent increases as the percentage of circular shapes increases which means that there was film discontinuity as the circular pores increases. Microstructurally, it can be assumed that there are more circular pores that cause discontinuity in current flow path at low water saturation, thus increasing the resistance of the rock.

Fig. 5 shows the RI- S_w for Bentheim sandstone at frequency range 0.1 to 100 kHz. As can be seen from the figure, at S_w range 0.1 to 1.0 a straight line was observed for frequency range 0.1 to 10 KHz, but at S_w below 0.1, the n values reduces which is in contrast with the observation from Berea sandstone where the values of n increased. In terms of microstructural properties of Bentheim, the pores are likely to have more of angular-shaped pores that favour continuity of thin film of water at low S_w .

Fig. 6 shows the RI- S_w data obtained from Mount Gambier carbonate plots. At S_w range

of 0.25 to 1.0, the RI- S_w relationship follows straight line paths as predicted by Archie equation[6]. But at water saturation below 0.25, the RI- S_w curve deviated downwardly. This observation for a carbonate reservoir is usually triggered by presence of micropores. The relative volume of micropores is a major factor controlling S_w and the corresponding resistance. This is due to their intricate pore geometry, giving rise to complex resistivity index curves and it is difficult to describe by a simple Archie law. The non-Archie behavior of carbonate rocks at low water saturation have been investigated by many researchers experimentally[27-32]. According to the experiments conducted by Dixon and Marek[28], the micropores remain water-filled and continue to provide electrically-conductive networks as S_w decreases. Most laboratory experiments on RI- S_w studies are conducted at a desaturation pressure less than capillary entry pressure for micropores, thus the micropores still retain the water in its pores until the entry pressure is exceeded.

From Figs. 4-6, it could be seen that at frequency from 0.1 kHz to 10 kHz and water saturation from 0.25 to 1.0, all the experimental data from this study were not affected by frequency. But at frequency of 100 kHz, the resistivity index deviated from the normal straight line at water saturation range of 0.4 to 0.65 for all the rocks used in this study. Garrouch and Sharma[34] have reported this effect, that at high frequency n tends to de-

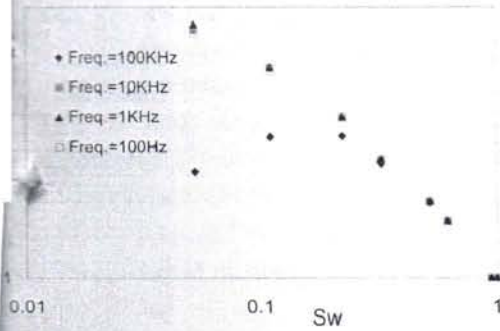

Figure 6: RI- S_w for Mount Gambier Carbonate.

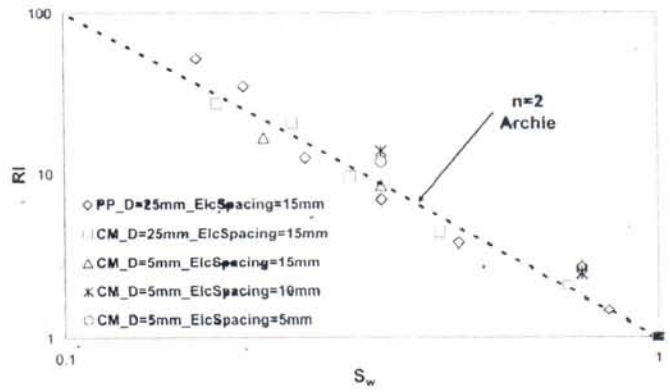

Figure 7: RI- S_w for Berea Sandstone.

se with an increase in frequency. The results from frequency test guided us in choosing the right frequency to investigate the effect of frequency and electrode spacing on RI- S_w relation-

Effects of Size and Electrode Spacing

Electrical resistivity measurements were performed on A-samples using the porous plate desaturation technique and B-samples using the centrifuge desaturation technique for all the model samples. Centrifuge desaturation techniques were used for A- and B-samples because the porous plate technique could not be used for B-samples effectively due to its smaller diameter. The centrifuge desaturation technique was calibrated with the porous plate data for A-samples. After the experiments on A-samples, the centrifuge technique was extended to B-samples. Electrode spacing in B-samples was then varied from 5mm to 15mm. All data were taken at 1.0 Hz. The resistivity index and corresponding water saturations obtained are plotted for Berea, Bentheim and Mount Gambier rocks in Figs. 7-9 for both porous plate and centrifuge desaturation techniques.

The resistivity index (RI) - water saturation (S_w) data obtained from A-samples using both porous plate and centrifuge desaturation techniques for all samples are all in agreement with each other, which shows that centrifuge-desaturation technique can be used for experi-

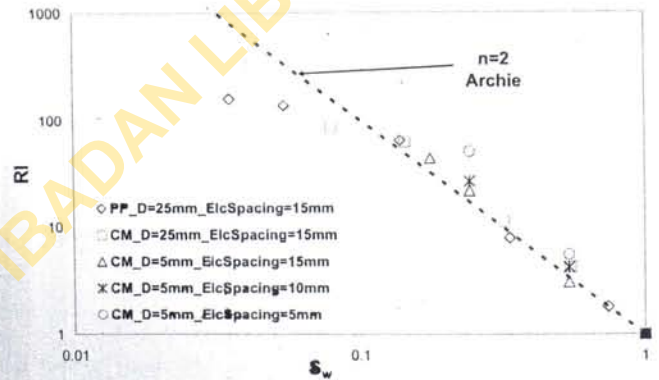

Figure 8: RI- S_w for Bentheim Sandstone.

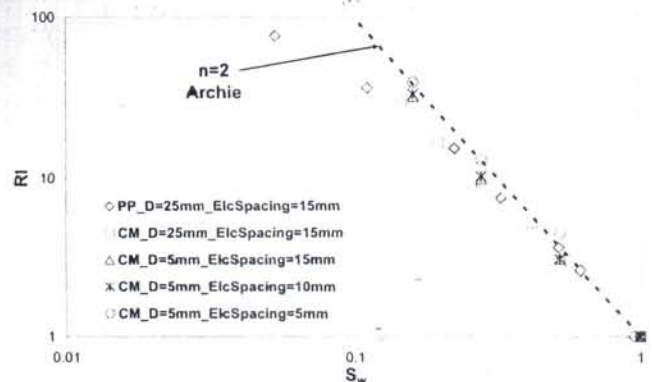

Figure 9: RI- S_w for Mount Gambier Carbonate.

ments with small sized samples. Table 2 shows the calculated saturation exponents for all the samples used in this study.

Results from B-sample for Berea sandstone at 15mm-electrode spacing agrees with the data obtained from A-sample using both techniques, but the saturation exponents calculated from 10mm- and 5mm-electrode spacing were higher than 15mm-electrode spacing. The same observation was made on Bentheim sandstone Table 2. Only 5mm-electrode spacing in Mount Gambier carbonates that the saturation exponent is higher and the 10mm-electrode spacing agrees with other data. High saturation exponents in these rocks are attributed to interference in magnetic field due to close distance in the potential electrodes. This may also be attributed to poor connectivity of the portion of Mt. Gambia rock used. Carbonate rocks are difficult to characterize due to their micropores. The results for the sandstones are as reported in the literature for capillary pressure and spontaneous imbibition measurements[4,5].

4. Conclusions

A detailed literature review has shown that experiments at the micro-CT scale is still lacking. Experimental results show that commonly used homogeneous rock types such as Berea and Bentheim sandstones and Mount Gambier carbonate can be considered to be sufficiently homogeneous from the current micro-CT scale to the conventional core scale. Hence, experimental data taken from these rocks of conventional core plug scale can be used to calibrate micro-CT based network models for two phase flow properties. Once validated, the micro-CT imaging technique can provide the opportunity to use small rock fragments from cores, sidewall cores and recovered drill cuttings to make realistic predictions for two-phase flow properties using network modelling.

The frequency used in laboratory measurement of electrical resistivity should not exceed 10kHz. The measurement of electrical resistivity index on small core samples having similar scales as micro-CT imaging can be made accurately in the laboratory. However, the electrode spacing as low as 5mm and core samples diameters 5mm is still challenging.

5. Recommendations

It has been proven that commonly used outcrop rock types such as Berea and Bentheim sandstones and Mount Gambier carbonate can be considered to be sufficiently homogeneous from the micro-CT imaging scale to conventional core plug scale. This result needs to be compared with micro-CT based predictions.

The experimental data from this study is limited to outcrop samples, and hence, further investigation is required for reservoir rock. Especially, core analysis of carbonate reservoirs is a big challenge to tackle.

References

1. Auzeias F.M, Dunsmuir J, Ferreol J, Martys N, Olson J, Ramakrishnan, Rothman D.H and Schwartz L.M, Transport in Sandstone. A study based on three dimensional microtomography. *Geop. Res. Lett.* 23, 705-708, 1996.
2. Arns C.H, Knackstedt M.A, Pinczewski W.V and Lindquist W.B. Accurate quantification of transport properties from microtomographic images. *Geophysical Research Letters* 28, 3361-3364, 2001.
3. Knackstedt M.A, Arns C.H, Limaye Sakellariou M.A, Senden T.J, Sheppard Sok R.M, Pinczewski W.V, and G.F B. Digital core laboratory: Properties of reservoir core derived from 3D images. *Petroleum Tech* 56(5), 66, 2004.
4. Olafuyi, O.A., Sheppard, A. P., Arns H., Sok, R. M., Cinar, Y., Knackstedt

Table 2: Saturation exponents for all the rocks.

Sample	Berea	Bentheim	Mount Gambier
Porous Plate (D = 25mm; ES = 15mm)	1.992	2.03	1.8
Centrifuge (D = 25mm; ES = 15mm)	1.94	2.1	1.82
Centrifuge (D = 5mm; ES = 15mm)	2.06	2.14	1.81
Centrifuge (D = 5mm; ES = 10mm)	2.51	2.32	1.83
Centrifuge (D = 5mm; ES = 5mm)	2.40	2.78	2.1

* D: Diameter; ES: Electrode Spacing

- A. and Pinczewski, W. V. Experimental Investigation of Drainage Capillary Pressure Computed from Digitized Tomographic Images. *Int. Journal of Engineering Research in Africa*, Vol. 1, Page 1 - 10, 2010.
- Olafuyi, O.A., Cinar, Y., Knackstedt, M. A. and Pinczewski, W. V. Spontaneous Imbibition in Small Cores, *Int. Journal of Petroleum Science and Technology*, Vol. 3 Number 1, Page 65 - 82, 2009.
 - Archie, G. E. The Electrical Resistivity Log as an Aid in Determining Some Reservoir Characteristics. *Trans AIME*, 146, 54 - 67. No Date
 - Sprunt, E.S., Hensel, W. M., York, C. E., and Honarpour, M. M. Compilation of Electrical Resistivity Measurements Performed by Twenty-Five Laboratories. *The Log Analyst*, 29: 13 - 29, 1988.
 - Worthington, P.F. Effect of Variable Saturation Exponent on the Evaluation of Hydrocarbon Saturation. *SPE Formation Evaluation*, Dec., 1992.
 - Worthington, P.F. An Electrical Analog Facility for Hydrocarbon Reservoirs. Presented at *ATCE - SPE 96718*, Dallas, Texas, 2005.
 - Worthington, P.F. Quality Assurance of the Evaluation of Hydrocarbon Saturation from Resistivity Data. Presented at *ATCE - SPE 103075*, San Antonio, Texas, 2006.
 - Fleury, M., and Longeron, D. Combined Resistivity and Capillary Pressure Measurements Using Micropore Membrane Technique. *JPSE*, 19: 73-79, 1998.
 - Cozzolino, K., Howard, A. Q., and Protazio, J. S. A New Look at Multiphase Invasion with Applications to Borehole Resistivity Interpretation. *Applied Geophysics*, 43: 91 - 100, 2000.
 - Roberts, J., Bonner, B., and Duba, A. Electrical Resistivity Measurements of Brine saturated Porous Media Near reservoir Conditions: Awibengkok Preliminary Results. Presented at the *Annual Meeting of the Geothermal Resources Council*, Nevada, 1999.
 - Sharma, M.M., Garrouch, A., and Dunlap, H. F. Effects of Wettability, Pore Geometry and Stress on Electrical Conduction in Fluid Saturated rocks. *The Log Analyst*, September - October, 1991.
 - Padhy, G.S., Ioannidis, M. A., Lemaire, C., and Coniglio, M. Measurement and Interpretation of Non-Archie Resistivity Behaviour in Model and Real Vuggy Carbonates. Presented at *SCA Meeting - SCA2006-11*, Norway, 2006.
 - Moss, A.K., Jing, X. D. And Archer, J. S. Wettability Of Reservoir Rock And Fluid Systems From Complex Resistivity Measurement. *6th Int. Sym. On Eval. Of Res. Wett.*, Socorro, New Mexico, USA, 2000.
 - Bona, N., Rossi, E., and Capaccioli, S. Electrical Measurements in the 100 Hz to 10 GHz Frequency range for Efficient Rock Wettability Determination. *SPE Journal*, March, 2001.
 - Longeron, D., Argaud, M. J., and Feraud, J. P. Effect of Overburden Pressure, Na-

- ture and Microscopic Distribution of Fluids on Electrical Properties of Rock Samples. *SPE Formation Evaluation*(June): 194 - 202, 1989.
- 9 Longeron, D. Laboratory Measurements of Capillary and Electrical Properties of Rock Samples at Reservoir Conditions: Effect of Some Parameters. *SCA Conference - SCA9023*, 1990.
10. Jing, X.D., Archer, J. S., and Daltaban, T. S. Laboratory Study of the Electrical and Hydraulic Properties of Rocks under Simulated Reservoir Conditions. *Marine and Petroleum Geology*, 9(April): 115 - 127, 1992.
21. Waxman, M.H., and Thomas, E. C. The Electrical Conductivity in Shaly Sands - I. The Relation between Hydrocarbon Saturation and Resistivity Index; II. The Temperature Coefficient of Electrical Conductivity. *Trans AIME*, 257, Feb, 1974.
22. De Waal, J.A., Smits, R. M. M., de Graaf, J. D. and Schipper, B. A.. Measurement and Evaluation of Resistivity Index Curves. *SPWLA Annual Symposium*, 1989.
23. Donaldson, E.C. and Siddiqui, T. K. Relationship Between the Archie Saturation Exponent and wettability. *SPE Formation Evaluation*, 4(3): 359 - 362, 1989.
24. Sondena, E., Brattell, F., Normann, H. P., and Kollveit, K. The Effect of Reservoir Conditions and wettability on Electrical Resistivity, Presented at *Asia-Pacific Conference - SPE 22991*, Perth, Australia, 1991.
25. Suman, R.J., and Knight, R. J. Effects of Pore Structure and Wettability on the Electrical Resistivity of Partially Saturated Rocks - A Network Study. *Geophysics*, 62(4): 1151 - 1162, 1997.
26. Arns, J.Y., Sheppard, A. P., Arns, C. H., Knackstedt, M. A., Yelkovich, A., and Pinczewski, W. V. Pore-Level Validation of Representative Pore Networks Obtained From Micro-CT Images. *SCA International Symposium - SCA2007-15*, Calgary, Canada, 2007.
27. Swanson, B.F. Microporosity in Reservoir Rocks: Its Measurements and Influence on Electrical Resistivity. *The Log Analyst*, 26(6): 42 - 52, 1985.
28. Dixon, J.R., and Marek, B. F. The Effect of Bimodal Pore Size Distribution on Electrical Properties of Some Middle Eastern Limestones. *SPE Annual Technical Conference and Exhibition - SPE 20601*, New Orleans, Louisiana, pp. 743 - 750, 1990.
29. Petricola, M.J.C., and Watfa, M. Effect of Microporosity in Carbonates: Introduction of a Versatile Saturation Equation. *Middle East Oil Show -SPE 29841*, Bahrain, 1995.
30. Ara, T.S., Talabani, S., and Vaziri, H. H. In-Depth Investigation of the Validity of the Archie Equation in Carbonate Rocks. *SPE Production and Operations Symposium - SPE 67204* Oklahoma City, Oklahoma, 2001.
31. Fleury, M. Resistivity in Carbonates: New Insights *SCA International Symposium - SCA2002-28*, 2002.
32. Masalmeh, S.K., and Jing, X. D. Carbonate SCAL: Characterisation of Carbonate Rock Types for Determination of Saturation Functions and Residual Oil Saturations. *SCA International Symposium*, Abu-Dhabi, UAE, 2004.
33. Cerepi, A. Electrical Behavior and Transport Properties in Carbonate Sedimentary Cores. *SCA Int. Symposium*, Abu Dhabi, 2004.
34. Garrouch, A.A., and Sharma, M. M. A Novel Study of the Dielectric Dispersion in Porous Media in the Frequency Range 10 Hz to 10MHz. *SCA International Symposium - SCA 9725*, 1997.
35. Al-Mahtot, O.B., and Mason, W. E. Effect of Fluid Characteristics and Flow Mechanism on Archie Saturation Exponent. *SCA Int. Symposium - SCA9841*, The Hague, Netherlands, 1998.

Olafuyi, O.A. Review of Electrical Resistivity Literature Experimental Data Available for Network Model Validation. *The Journal of Nig. Institution of Prod. Engineers*, Vol.10, July 2009, Pg. 34 - 50.

Olafuyi, O.A., Cinar, Y., Knackstedt, M. A. and Pinczewski, W. V. [70%] Spontaneous Imbibition in Small Cores. *Int. Journal of Petroleum Science and Technology*, Vol. 3 Number 1, Page 65 - 82, 2009.

Mohan, K., K., Vaidya, R. N., Reed; M. G., and Fogler, H. S. Water Sensitivity of Sandstones Containing Swelling and Non-Swelling Clays. *Colloids and Surfaces A: Physicochemical and Engineering Aspects*, 73(29): 237-254, 1993.

Anderson, W.G., Wettability Literature Survey-Part I: Rock/Oil/Brine Interactions and the Effects of Core Handling on Wettability. *JPT*, 1986: p. 1125-44.

UNIVERSITY OF IBADAN LIBRARY