

## VARIATION IN FIBRES AND VESSEL ELEMENTS OF *DELONIX REGIA* (CAESALPINIACEAE)

by

A. E. AYODELE & A. O. PEREIRA-SHETEGLU

Department of Biological Sciences, University of Lagos,  
Lagos, Nigeria.

Received. 30-IV-1993.

### SUMMARY

Variation in fibres and vessel elements of the secondary xylem of *Delonix regia* has been investigated by light microscopy. This work clearly establishes inter-positional variation in the dimensions, particularly of the fibres both axially and radially. Generally, the longest and widest fibres are recorded at the breast height of 1.30 m from the base of the plant. The widest but shortest fibres occur towards the pith while the thinnest but longest fibres are found towards the periphery. The widest and longest vessels are also found at the breast height of 1.30 m from the base of the plant. The importance of these variable characters in the taxonomy of the taxon is discussed.

### INTRODUCTION

*Delonix regia* (Boj. ex Hook.) Raf. is a common ornamental plant known in West Africa as «Flame of the Forest» or «Flamboyant» but now subsponaneous in many localities (HUTCHINSON & DALZIEL, 1954). The plant is a widely grown decorative tree and a native of Madagascar but now grown in all parts of the tropics. The leaves are compound bipinnate with small and feathery leaflets. Flowers are bright scarlet mixed with yellow, in colour, and comprise of 10 stamens with long, red filaments (IRVINE, 1961). Timber obtained from this plant is reported to be fairly resistant to moisture and insects. Also, the stem exudes yellow or reddish-brown latex which is a source of watersoluble

gum (IRVINE, 1961). Furthermore, the bark of the stem is reputed for its medicinal purposes in Indo-China (BURKILL, 1935).

Studies in the cell dimensions of wood particularly the fibres and vessel elements have shown that the cells vary in their dimensions with respect to their positions in the plant. The works of HARTIG, STAUFFER, as well as, PRITCHARD & BAILEY (cf. DINWOODIE, 1961) lay credence to this fact. In some of the species studied by them, they observed a progressive decrease in wood fibre length with increase in height of the plant from the base of the trunk to the apex. BISSET & DADSWELL (1949) showed that fibres increase in length from the centre of the trunk outwards within one tree of *Eucalyptus regnans* F. V. M.

In both gymnosperms and angiosperms, BISSET & DADSWELL (1950) also found the length of the elongated types of cells, such as tracheids and fibres, increases from the first formed early wood to the last formed late wood. PHILIPSON & BUTTERFIELD (1967) stated that the shorter elements found at the top of the tree occur as a result of the trend of horizontal length variation from cambium to periderm which varies in the vertical direction to such an extent that a reduction in cell length occurred along with enhanced radial growth. The aim of this work, therefore, is to investigate the variation which occurs in the dimension of fibres and vessel elements, radially and axially in *D. regia*, as a contribution to the taxonomy of the species.

#### MATERIALS AND METHOD

A large tree of *D. regia* was felled at the Obafemi Awolowo University, Ile-Ife, Nigeria, by cutting it at ground level and the stem marked at intervals of 0.20 m, 1.30 m and 2.60 m (breast height), and 3.00 m, 3.60 m, 4.10 m and 4.40 m from the ground level on the bole towards the highest branch. Wood discs of about 7.50 cm thick were sliced-off from these marked points and used to determine the radial variation in the cell dimensions. The discs were marked at three points, viz. 1.50 cm, 3.50 cm and 5.50 cm, from the periphery towards the pith. Pieces of wood were chipped off from these points, cut into thin slices and macerated in SCHULTZE's fluid [2% Potassium trioxonitrate (V) dissolved in concentrated trioxonitrate (V) acid]. For the maceration technique, the materials were placed in glass vials and

the macerating liquid added and the set-up were kept in the fume chamber in the laboratory.

Pieces of wood were also taken from other marked points and macerated so as to determine variation along the height of the stem. After about 45 minutes, the materials were removed from the macerating liquid, washed thoroughly in several changes of distilled water and stored in 70 % ethanol. For cell measurements, small pieces of macerated wood were stained in Toluidine blue and mounted in 25 % glycerol. For each sample, 50 wood fibres and 20 vessel elements were chosen randomly and measured using a micrometer eye-piece. For each quantitative character, the mean, standard deviation and standard error were determined.

## RESULTS AND DISCUSSION

The results obtained from the method of investigation reveal a number of interesting features. Fibre size and cellwall thickness vary considerably through the entire plant. At point 1.50 cm from the periphery, the longest fibre of 1121.90  $\mu\text{m}$  is recorded at point B, which is 1.30 m from the base of the plant (Fig. 1). But the shortest fibre of 924.50  $\mu\text{m}$  occurs at point D, which is 3.00 m from the base (Table 1). Similar results are obtained at point 3.50 cm from the periphery as the longest and shortest fibres of 1069.40  $\mu\text{m}$  and 855.40  $\mu\text{m}$  respectively occur at points B and D. However, at point 5.50 cm from the periphery, the longest fibre of 1060.80  $\mu\text{m}$  occurs at point B but the shortest fibre of 716.20  $\mu\text{m}$  is recorded at point E (Table 1).

At point 1.50 cm from the periphery, the widest fibre of 33.40  $\mu\text{m}$  occur at point B while the smallest fibre of 23.90  $\mu\text{m}$  occurs at point E (Table 1). Similarly, at point 3.50 cm from the periphery, the widest and the narrowest fibres of 33.40  $\mu\text{m}$  and 23.40  $\mu\text{m}$  respectively occur at points B and E. However, at point 5.50 cm from the periphery, the widest fibre of 37.00  $\mu\text{m}$  occurs at point B while the narrowest fibre of 25.20  $\mu\text{m}$  occurs at point D (Table 1). At point 1.50 cm from the periphery, the thickest fibre wall of 7.50  $\mu\text{m}$  occurs at point C while the thinnest fibre of 5.50  $\mu\text{m}$  is recorded at point B (Table 1). At point 3.50 cm from the periphery, the thickest wall of 7.30  $\mu\text{m}$  is recorded at point F while the thinnest 5.50  $\mu\text{m}$  occurs at point G.

At point 5.50 cm from the periphery, the thinnest wall of  $6.20 \mu\text{m}$  occurs at point G while the thickest wall of  $7.50 \mu\text{m}$  is recorded at point F (Table 1).

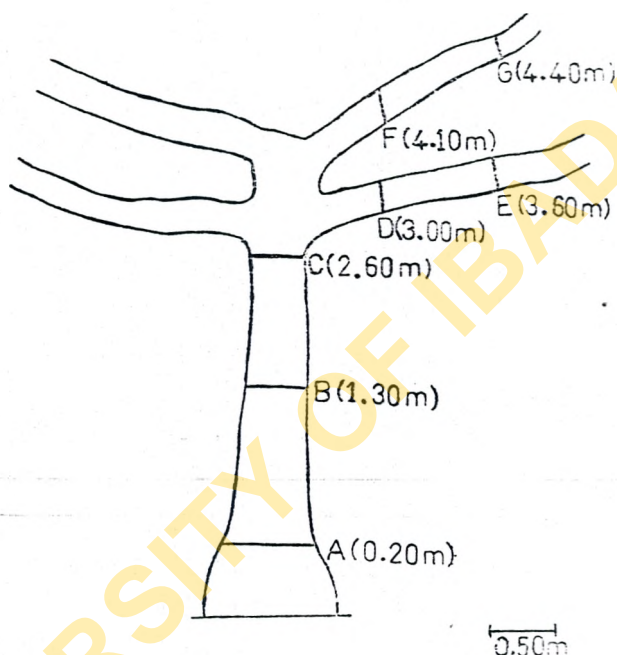

Fig. 1. — Semi-diagrammatic sketch of *D. regia* showing the different sampling points on the stem and branches.

The size of vessels also vary considerably at the different points examined. The variation recorded is from  $251.30 \mu\text{m}$  at point B to  $148.80 \mu\text{m}$  recorded at point D. Similarly, the width varies from  $28.20 \mu\text{m}$  at point D to  $98.50 \mu\text{m}$  at point B (Table 2). It would be observed that the fibre length decreases from the base of the plant upwards to the top. This is in conformity with the proposition of PHILIPSON & BUTTERFIELD (1967). They attributed this to changes that occur in the cambium leading to the formation of the periderm. Also, this is in agreement with the suggestion of BISSET & DADSWELL (1950) that elongated types of cells increase in length from the first formed early wood (those at the periphery) to the last formed late wood.

TABLE 1

Variation in fibre sizes and cellwall thickness

Distance from top of plant base (metres)	1.50			3.50			5.50		
	Mean size $\pm$ Std. error ( $\mu\text{m}$ )								
	F. L. $\pm$ S. E.	F. W. $\pm$ S. E.	C. T. $\pm$ S. E.	F. L. $\pm$ S. E.	F. W. $\pm$ S. E.	C. T. $\pm$ S. E.	F. L. $\pm$ S. E.	F. W. $\pm$ S. E.	C. T. $\pm$ S. E.
G (4.40)	993.60 $\pm$ 33.40	26.00 $\pm$ 0.60	6.80 $\pm$ 0.40	880.30 $\pm$ 36.90	26.00 $\pm$ 1.60	5.50 $\pm$ 0.30	901.00 $\pm$ 53.70	26.30 $\pm$ 1.40	6.20 $\pm$ 0.40
F (4.10)	965.80 $\pm$ 42.20	27.80 $\pm$ 1.10	7.00 $\pm$ 0.40	964.80 $\pm$ 21.10	27.30 $\pm$ 1.10	7.30 $\pm$ 0.50	937.00 $\pm$ 52.30	30.90 $\pm$ 1.50	7.50 $\pm$ 0.60
E (3.60)	974.40 $\pm$ 49.50	23.90 $\pm$ 0.90	5.90 $\pm$ 0.40	913.00 $\pm$ 44.50	23.40 $\pm$ 1.10	5.70 $\pm$ 0.40	716.20 $\pm$ 37.40	27.00 $\pm$ 1.00	6.80 $\pm$ 0.40
D (3.00)	924.50 $\pm$ 39.90	26.00 $\pm$ 0.50	6.20 $\pm$ 0.40	855.40 $\pm$ 61.60	25.20 $\pm$ 0.40	6.50 $\pm$ 0.70	721.90 $\pm$ 46.40	25.20 $\pm$ 0.70	6.80 $\pm$ 0.40
C (2.60)	1106.50 $\pm$ 23.70	29.10 $\pm$ 0.60	7.50 $\pm$ 0.20	1027.00 $\pm$ 18.90	27.10 $\pm$ 0.30	6.80 $\pm$ 0.20	1014.70 $\pm$ 19.20	28.90 $\pm$ 0.40	6.80 $\pm$ 0.20
B (1.30)	1121.90 $\pm$ 28.20	33.40 $\pm$ 0.60	5.50 $\pm$ 0.20	1069.40 $\pm$ 25.00	33.40 $\pm$ 0.80	5.90 $\pm$ 0.20	1060.80 $\pm$ 20.70	37.00 $\pm$ 0.60	6.60 $\pm$ 0.20
A (0.20)	1035.50 $\pm$ 24.40	27.90 $\pm$ 0.50	6.80 $\pm$ 0.20	1020.30 $\pm$ 20.60	28.70 $\pm$ 0.50	7.00 $\pm$ 0.20	970.10 $\pm$ 17.80	29.50 $\pm$ 0.60	7.10 $\pm$ 0.30

F. L. — Fibre length; F. W. — Fibre width; C. T. — Cell wall thickness.

The concentration of the longest and widest fibres at the breast (1.30 m) may not be unconnected with the burden of the load of the vegetative and floral parts shouldered by that portion of the plant. However, the age of a tree as in *D. regia* is likely to influence the dimensions and general structure of

TABLE 2  
Variation in vessel sizes

Height from plant base (metres)	Mean vessel size $\pm$ STD error ( $\mu$ m)	
	Length	Width
G (4.40)	154.20 $\pm$ 15.20	46.60 $\pm$ 4.20
F (4.10)	153.10 $\pm$ 12.30	35.00 $\pm$ 2.00
E (3.60)	168.30 $\pm$ 16.30	69.20 $\pm$ 11.50
D (3.00)	148.80 $\pm$ 21.60	28.20 $\pm$ 2.40
C (2.60)	163.70 $\pm$ 10.90	39.70 $\pm$ 1.90
B (1.30)	251.60 $\pm$ 19.90	98.50 $\pm$ 17.00
A (0.20)	203.70 $\pm$ 21.60	60.40 $\pm$ 11.70

the individual elements in the tree. This work has clearly established interpositional variation in the dimensions particularly of the fibres both axially and radially. Variation in fibre length and width along the tree axially and radially is generally accepted to be connected with the changes in size of the fusiform initials of the cambium (DINWOODIE, 1961). This is because the secondary xylem is always affected by the irregular activity of the cambium, a factor which is in itself dictated by season.

#### ACKNOWLEDGEMENTS

The authors wish to thank Dr. O. A. OLATUNJI and Dr. W. M. KPIKPI of the Department of Botany, Obafemi Awolowo University, Ile-Ife, for their useful contributions and suggestions.

#### REFERENCES

- BISSET, I. J. W. & DADSWELL, H. E.  
 1949 The variation of fibre length with one tree of *Eucalyptus regnans* F. V. M. *Australian Forestry* 13: 86-89.  
 1950 The variation in cell length within one growth of certain angiosperms and gymnosperms. *Australian Forestry* 14: 17-29.

BURKILL, I. H.

1935 *Economic Products of Malaya Peninsula*. Oxford University Press, London.

DINWOODIE, J. M.

1961 Tracheid and Fibre length in timber. A review of literature *Forestry* 34: 125-144.

HUTCHINSON, J. & DALZIEL, J. M.

1954 *Flora of West Tropical Africa*. Vol. I. Part 2. Crown Agents for Overseas Govt., London.

IRVINE, F. R.

1961 *Woody Plants of Ghana*. Oxford University Press, London.

PHILIPSON, W. R. & BUTTERFIELD, B. G.

1967 A theory of the causes of size variation in wood elements. *Phytomorphology* 17: 155-159.

UNIVERSITY OF IBADAN